

M-TEK CONCRETE BOLT DOWN FOOT



CSR

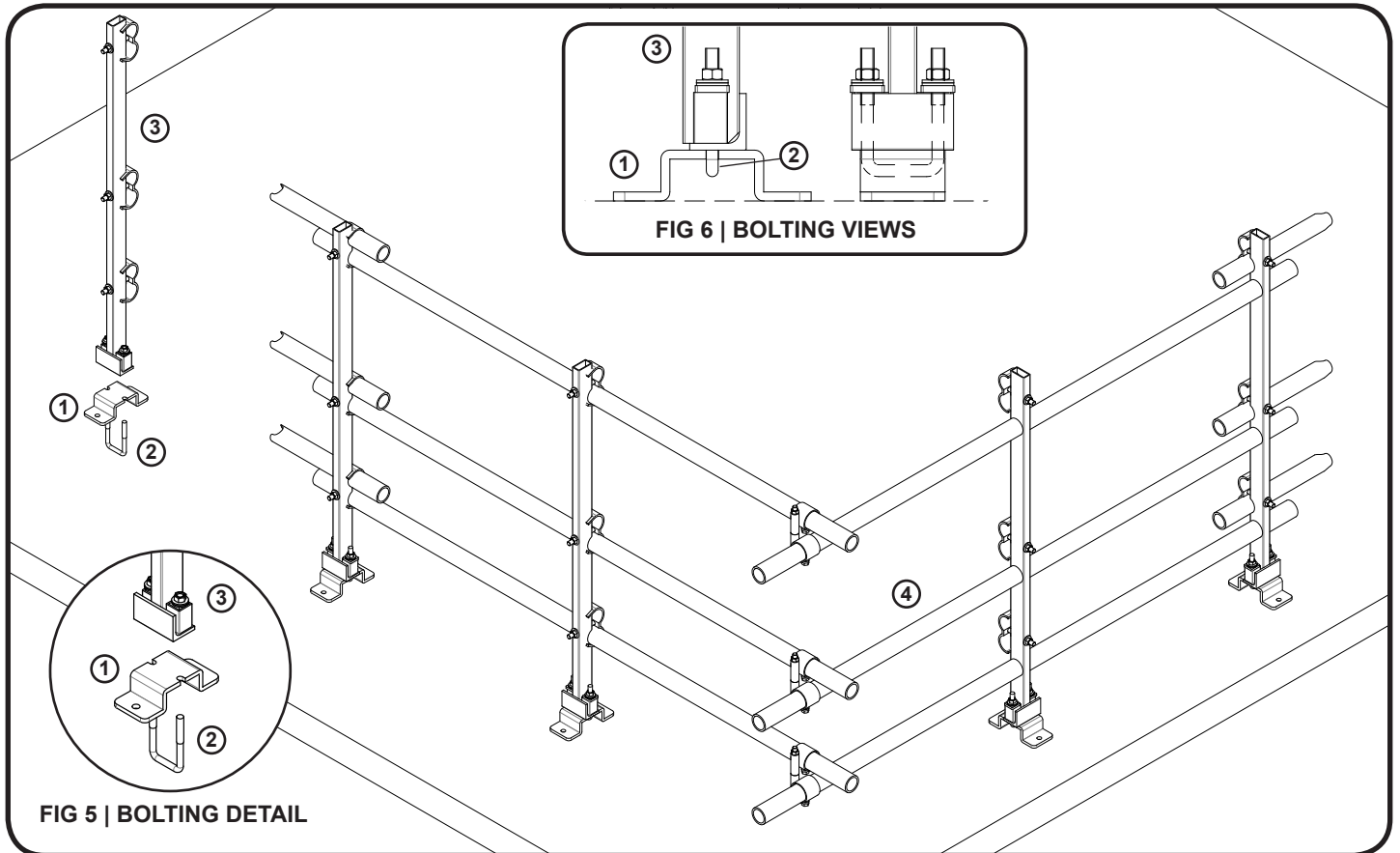

FIG 1 | SYSTEM ASSEMBLY

SYSTEM ASSEMBLY

STAGE 1 – CONCRETE BOLT DOWN FOOT ASSEMBLY

The Concrete Bolt Down Foot (1) is made of pressed 8mm mild steel, the plate has one notch machined on each side, these notches allow the M-Tek U-bolt (2) to pass through. See Figs 5 & 6.

The Concrete Bolt Down Foot has one 13mm hole drilled through both ends, by utilising these holes, drill 8mm hole into the concrete approximately 80mm deep. Apply one M8 x 60mm concrete bolts in each hole and tighten to secure to floor. See Figs 5 & 6.

STAGE 2 – M-TEK POST

Undo the post U-Bolt completely and remove it from the M-Tek Post (3) next slip the Concrete Bolt Down Foot over the U Bolt with the rail clamps facing inwards. See Figs 5 & 6. Tighten the Post U-Bolt nuts.

STAGE 3 – SPACING

Repeat “Concrete Bolt Down Foot Assembly” and “M-Tek Post” stage ensure the distance between post centres does not exceed 3.0 metres.

STAGE 4 – RAILS

Attach top, middle and bottom rails (4) to the M-Tek Post.

If required there are provisions to fit mesh panels or kick boards.

Continuous Rail Linkage – see Fig 2. Use Rail Clamps on M-Tek Post.

Angled Rail Linkage Joggle or Chain Joggle – See Figs 3 & 4. Use Joggle to link and clamp rails at a corner or cross junction.

Rails must overlap at least 100mm on each side of the joggle.

Ensure that all bolts are tight before use.

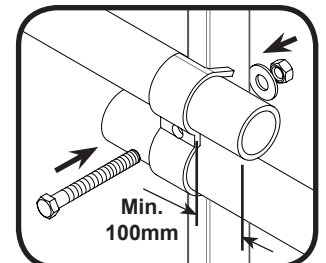

FIG 2 | CONTINUOUS RAILS

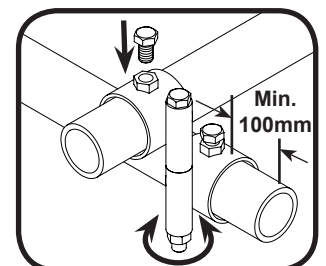

FIG 3 | LINKAGE JOGGLE

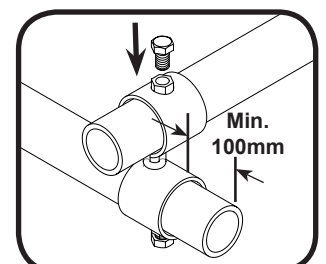

FIG 4 | CHAIN JOGGLE

1300 377 233

www.csrroofing.com.au

TopCat Safety Rail is a division of CSR Building Products Ltd. ABN 55008631356. Chatswood NSW 2067.