

ITEM	DWG	TITLE	QTY	MASS
1	N/A	M10 x 170mm CUP HEAD BOLT	2	0.2 kg
2	RRS-101	UNIVERSAL PLATE	1	0.8 kg

MASS: 1.0 kg

REV	DESCRIPTION / CHANGES	BY	APP'D	DATE

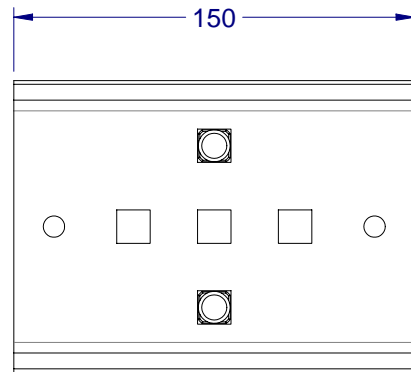

TOP VIEW

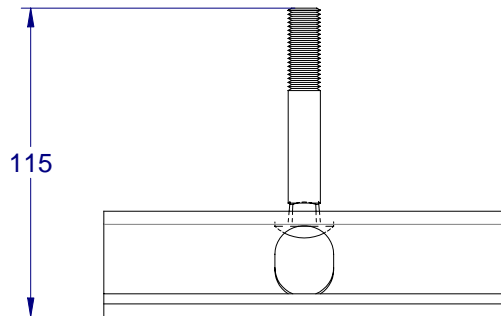

FRONT VIEW

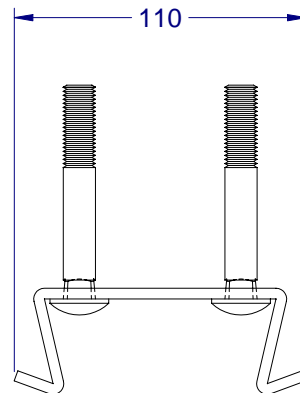

SIDE VIEW

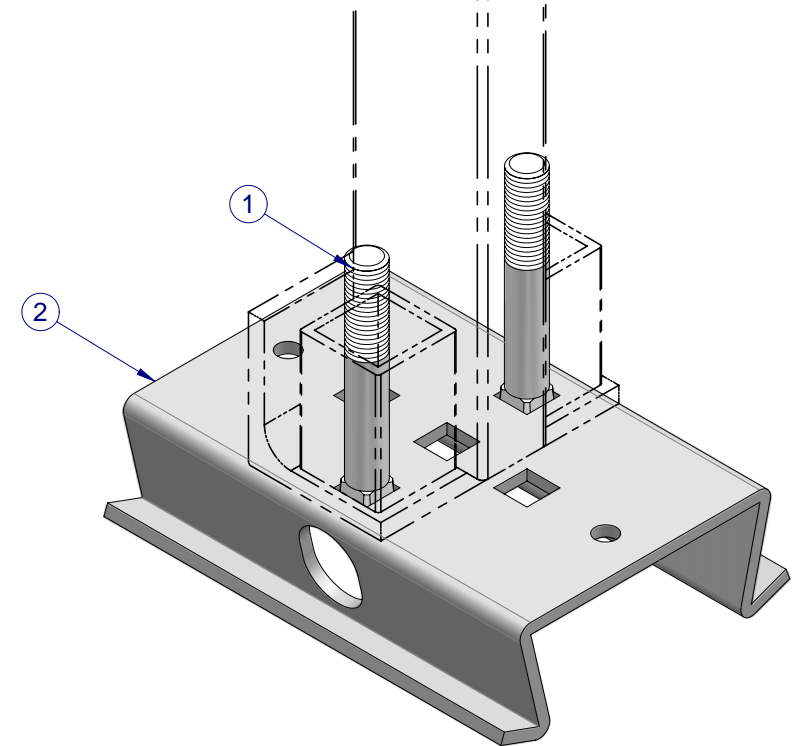

ISOMETRIC VIEW

GENERAL WELDING NOTES:
 1- ALL WELDS ON OUTSIDE SURFACES ONLY
 2- MAINTAIN ALL HOLLOW SECTIONS
 3- THICK LINES ON ISO VIEWS SHOW VISIBLE WELD LOCATIONS ONLY



www.csrroofing.com.au

130 Gilba Road
 Girraween NSW 2145
 Ph. (02) 9896-5250
 Fax (02) 9495-7910



COPYRIGHT 2007 TOPCAT / CSR
 WARNING: Copyright in this drawing remains the property of TOPCAT / CSR and copying in whole or part is not permitted without the written authority of the copyright owner

TOLERANCES
 (Unless otherwise noted)
 Whole: ± 0.25 mm
 Decimal: ± 0.1 mm
 Angular: ± 0.25 deg.

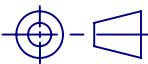

Third Angle Projection
 AS 1100

MATERIAL NOTES:
 ALL STEEL TO COMPLY WITH AS1163 GRADES C350L0 & C450L0



Denotes Critical Dimension

ALL FINISHES HOT-DIP GALVANIZED FINISH UNLESS OTHERWISE SPECIFIED - PROVIDE DRAINAGE HOLES WHERE NECESSARY IF NOT ALREADY DRAWN

All Dimensions Are In Millimetres
 Break All Sharp Corners and Remove Burrs & Swarf

DATE: 29/03/2007
 DRN: *CJM*
 APPROVED:

TITLE: SCREW DOWN ROOF SYSTEM
SCREW DOWN ROOF SYSTEM ASSEMBLY

MATERIAL: **SEE NOTES**

FINISH: **SEE NOTES**

SCALE: D.N.S

DWG No: **SDR-001**

REV No: **A3 1**

SHEET 1 of 1