

ITEM	DWG	TITLE	QTY	MASS
1		SAFETY CLAMP ASSEMBLY	3	1.4 kg
2	N/A	M12x40 SET SCREW	8	0.0 kg
3	SRS-903	B-TEK GABLE	1	4.6 kg
4	SRS-905	B-TEK ADJUSTER	1	1.3 kg
5	SRS-907	NEEDLE	1	5.1 kg
6	SRS-908	ADJUSTABLE CLAMP	2	4.0 kg

MASS: 16.8 kg

REV	DESCRIPTION / CHANGES	BY	APP'D	DATE

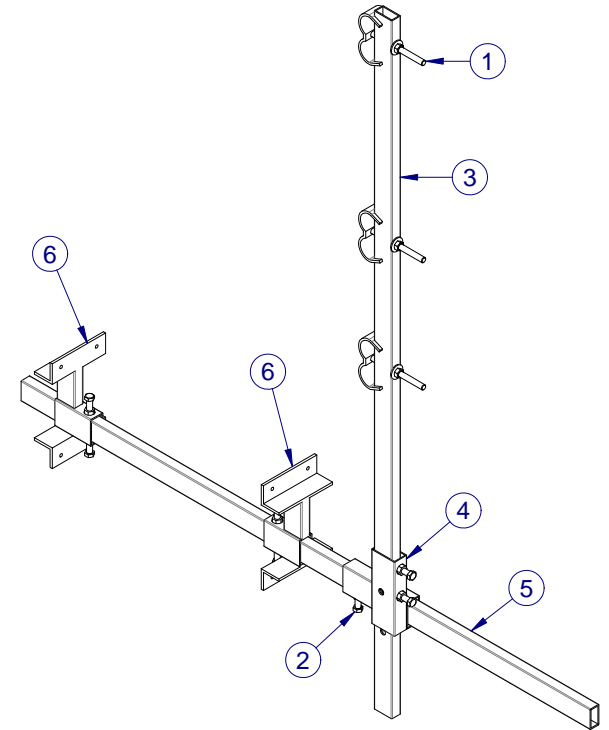
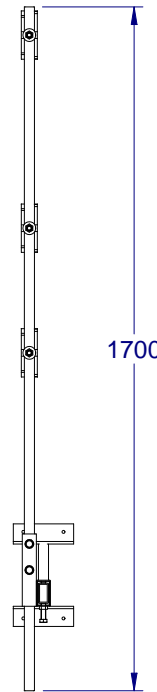
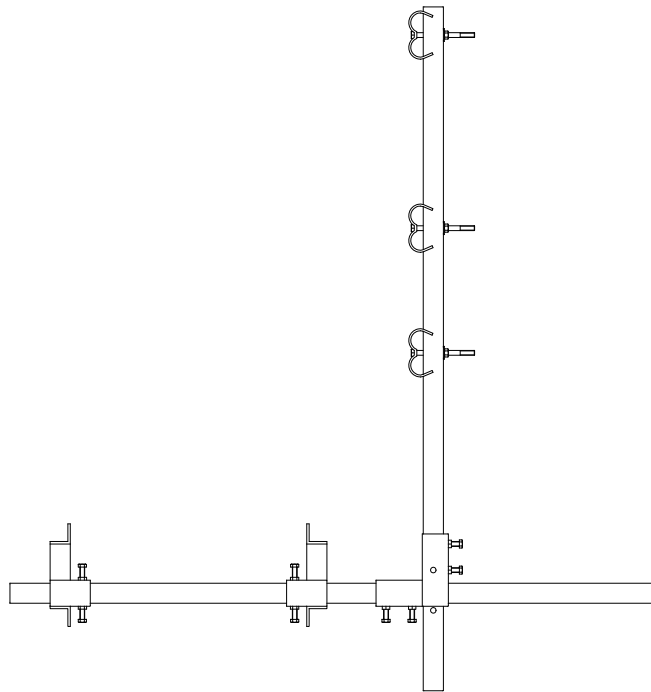
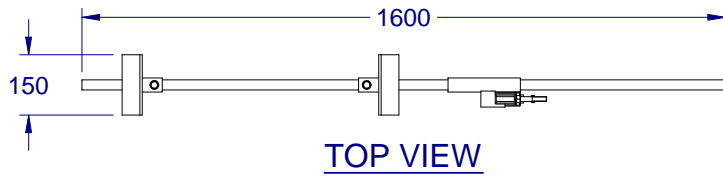

ISOMETRIC VIEW

GENERAL WELDING NOTES:
 1- ALL WELDS ON OUTSIDE SURFACES ONLY
 2- MAINTAIN ALL HOLLOW SECTIONS
 3- THICK LINES ON ISO VIEWS SHOW VISIBLE WELD LOCATIONS ONLY

FRONT VIEW

SIDE VIEW



www.csrroofing.com.au

130 Gilba Road
 Girraween NSW 2145
 Ph. (02) 9896-5250
 Fax (02) 9495-7910



COPYRIGHT 2005 TOPCAT / CSR
 WARNING: Copyright in this drawing remains the property of TOPCAT / CSR and copying in whole or part is not permitted without the written authority of the copyright owner

TOLERANCES
 (Unless otherwise noted)
 Whole: ± 0.25 mm
 Decimal: ± 0.1 mm
 Angular: ± 0.25 deg.

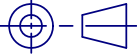

Third Angle Projection
 AS 1100

MATERIAL NOTES:
 ALL STEEL TO COMPLY WITH AS1163 GRADES C350L0 & C450L0



Denotes Critical Dimension

ALL FINISHES HOT-DIP GALVANIZED FINISH UNLESS OTHERWISE SPECIFIED - PROVIDE DRAINAGE HOLES WHERE NECESSARY IF NOT ALREADY DRAWN

All Dimensions Are In Millimetres
 Break All Sharp Corners and Remove Burrs & Swarf

DATE: 31/07/2007
 DRN: CJM
 APPROVED:

TITLE: TEK SERIES COMMERCIAL SAFETY RAIL SYSTEM B-TEK GABLE ASSEMBLY

MATERIAL: SEE PARTS
 FINISH: SEE PARTS

DWG No: SRS-901
 SCALE: D.N.S

A3
 SHEET 1 of 1

REV No: 1